

**Victor**



**DOWDING & PLUMMER Ltd.**

CALTHORPE HOUSE, STOCKFIELD ROAD,  
BIRMINGHAM B27 6AP – ENGLAND

TEL: 0121-706-5771 FAX: 0121-708-1052

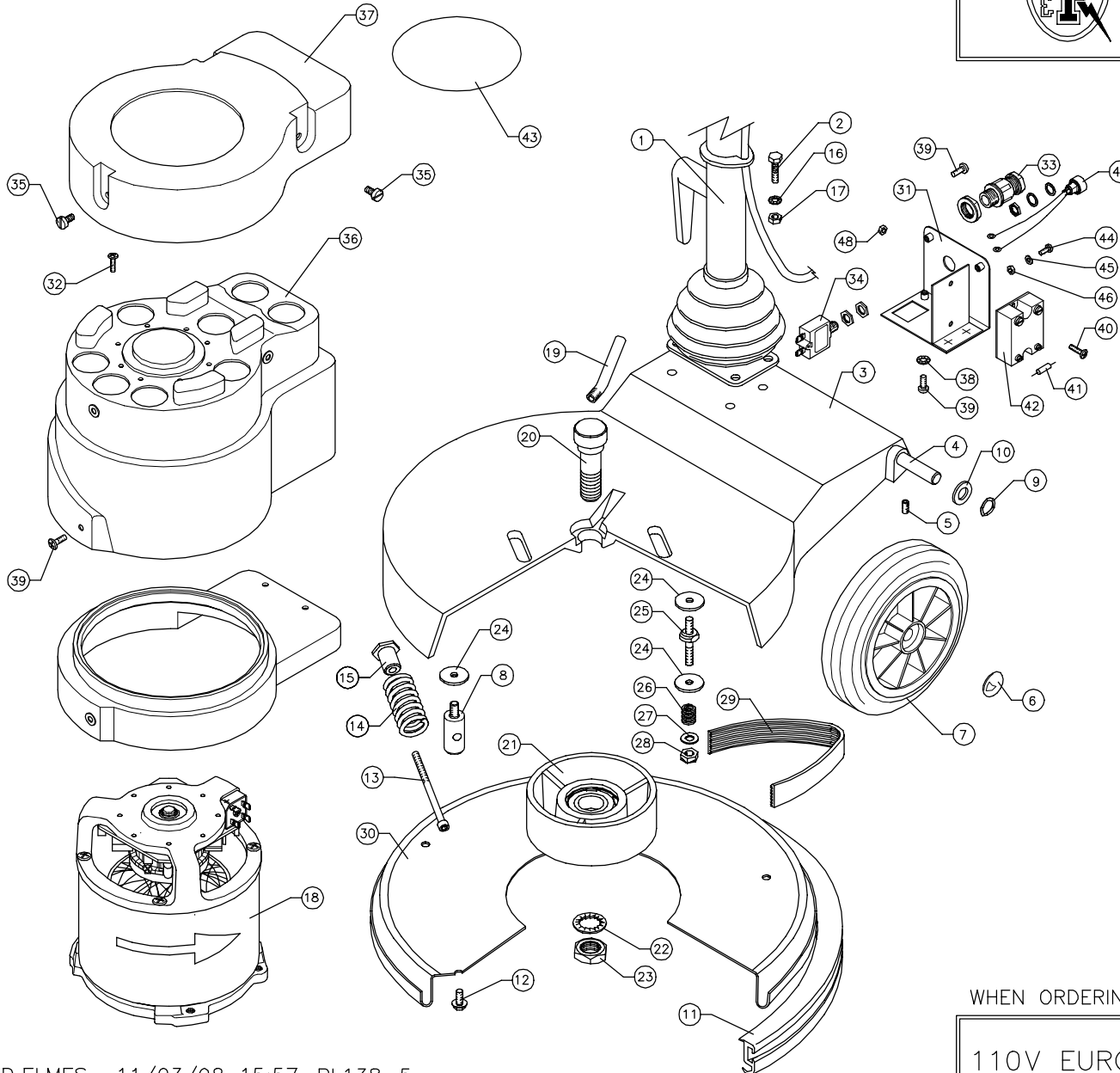

ITEM	PART No.	QTY.	DESCRIPTION
1	AYH1810	1	HANDLE ASSY.
2	M8X30BH	4	M8 x 30HEX HEAD SCREW
3	A1368/B/GH	1	BASE CASTING – GREY HAMMER
4	A1878/PLTD	1	380mm WHEEL AXLE – PLATED
5	M6X8SC	1	M6 x 8 SOCKET GRUB SCREW
6	SBI3005/A	2	12mm STARLOCK CAP
7	C1587	2	175mm WHEEL – REINFORCED BLACK
8	A1766	1	MOTOR PILLAR STUD
9	SBI3666	2	WAVEY WASHER – PLW4
10	M12W	2	12mm PLAIN WASHER
11	A1753/B/BL	1	54" Q/R BUFFER RING – BLACK
12	M6X12TT	5	M6 x 12 TAPTITE SCREW
13	A1864	1	BELT TENSIONING SCREW – M6x90
14	A1850	1	SPRING
15	A1865	1	SPRING RETAINER
16	M8WSP	4	M8 SPRING WASHER
17	M8N	4	M8 NUT
18	AYM2176	1	MOTOR ASSY. 1150w 110v 50hz
19	A1462/PLTD	1	WATER FEED PIPE–10mm PLATED
20	A1450/PLTD	1	PULLEY BOLT PLATED
21	AYP1016	1	ø157mm OUTPUT PULLEY ASSEMBLY
22	M20WSH	1	M20 SHAKEPROOF WASHER
23	M20N	1	M20 FULL NUT
24	A1378	7	WASHER (30x9x2.5mm)
25	A1843	3	MOTOR STUD
26	A2132	3	MOTOR STUD SPRING
27	M8W	3	M8 PLAIN WASHER
28	M8NSB	3	M8 BINX STIFF NUT
29	SBI3823	1	220J16 POLYVEE DRIVE BELT
30	B1054/GH	1	BRUSH COVER PRESSING – 450mm
31	C1631	1	CABLE ENTRY PANEL
32	M4X12TT	4	M4X12 TAPTITE SCREW
33	SBI5833	1	M16 CABLE GLAND
34	SBI5500	1	12A CIRCUIT BREAKER
35	SBI6439	3	M6X12 NYLON PAN HEAD SCREW SLOTTED
36	C1632	1	MOTOR COVER
37	C1633	1	MOTOR TOP COVER
38	M5WSH	2	M5 SHAKEPROOF WASHER
39	M5X12BPP	5	M5X12 POZIPAN HEAD SCREW – BLACK
40	M4X10SP	2	M4X10 POZIDRIVE PANHEAD SCREW
41	SBI6361	1	RESISTOR 0.66W 56kOHM
42	SBI6353	1	SPEED CONTROLLER PSR 25
43	SBI5477	1	VICTOR WORLD MOTOR TOP LABEL
44	M4X10SPB	1	M4X10 SCREW POZIPAN BRASS
45	M4WB	1	M4 WASHER BRASS
46	M4NB	1	M4 NUT BRASS
47	C1537	1	SPEED CONTROLLER KNOB/LEAD ASSY

WHEN ORDERING PLEASE QUOTE PART No. AND PART DESCRIPTION

110V EUROPA 450 DRIVE ASSY VAR SP-VA258PM

FROM 11.03.98 TO

D.ELMES 11/03/98 15:57 PL138-5