

Victor



DOWDING & PLUMMER Ltd.

CALTHORPE HOUSE, STOCKFIELD ROAD,
BIRMINGHAM B27 6AP - ENGLAND

TEL: 0121-706-5771 FAX: 0121-708-1052

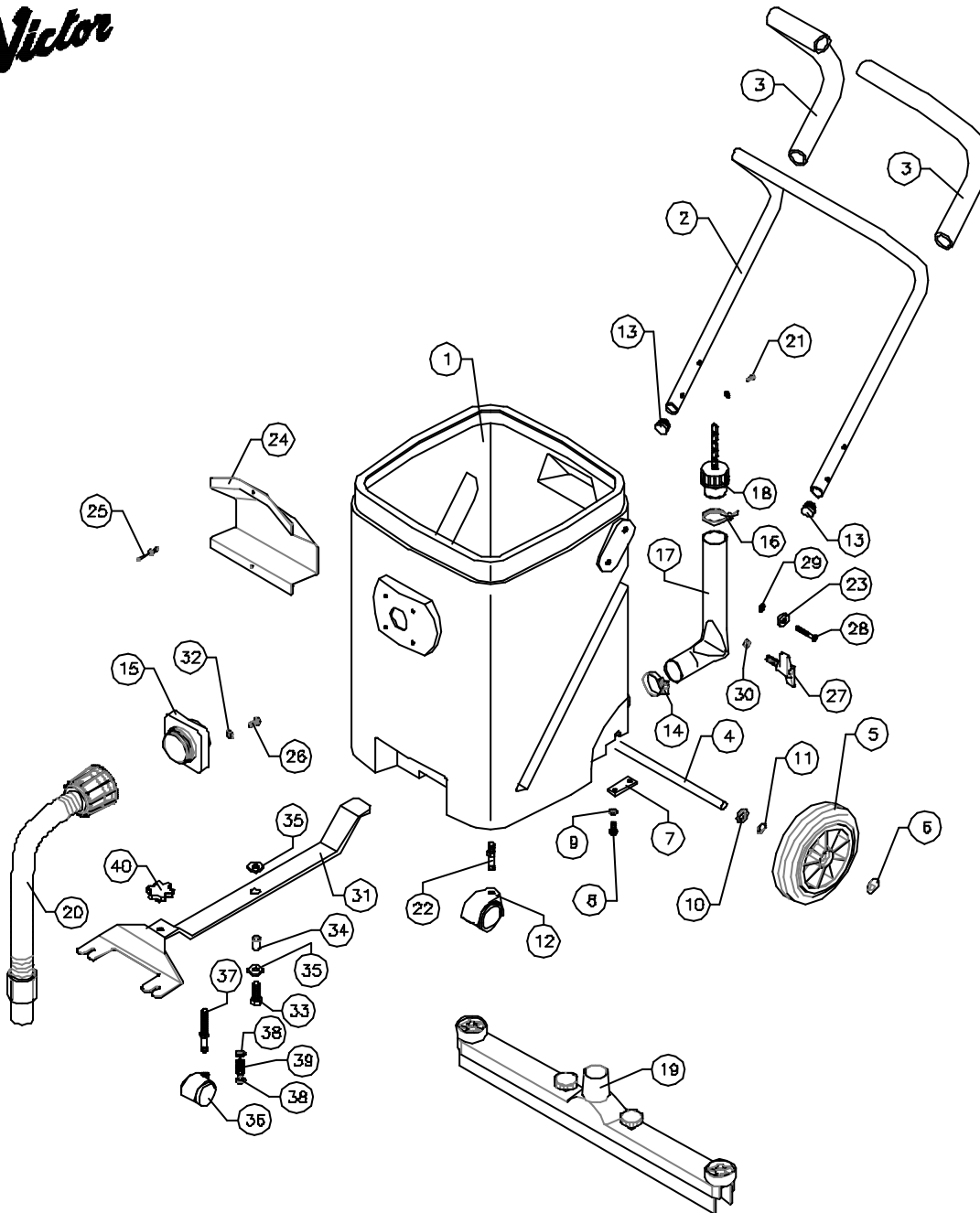

ITEM	PART No.	QTY.	DESCRIPTION
1	C1551	1	MAIN TANK 35L
2	C1606	1	HANDLE
3	C1607	2	HANDLE FOAMGRIP
4	A1879/PLTD	1	WHEEL AXLE PLATED
5	C1587	2	Ø175mm REINFORCED WHEEL
6	SBI3005/A	2	12mm STARLOCK CAP
7	C1581	2	WHEEL AXLE LOCATION PLATE
8	M8X18PP	4	M8 x 18 POZIPAN SCREW
9	M8WSH	4	M8 SHAKEPROOF WASHER
10	M12W	2	M12 PLAIN WASHER
11	SBI3066	2	WAVEY WASHER - PLW4
12	SBI6400	2	Ø50 TWIN RUBBER WHEEL CASTOR
13	SBI6305	2	Ø22 TUBE END PLUG
14	SBI6442	1	Ø40 JUBILEE HOSE CLIP
15	C1805	1	TUB INTAKE RADIUS
16	SBI5015	1	4.8 x 370 CABLE TIE
17	D0143B	1	FLAT LAY DUMP HOSE
18	C1635	1	DUMP HOSE CAP ASSY
19	AYN1002	1	SQUEEGEE ASSEMBLY
20	AYN2031	1	WVN35 HOSE ASSY
21	M4X12PP	1	M4 x 12 POSI PAN HEAD SCREW
22	SBI6399	2	CASTOR STUD
23	SBI6433	2	SADDLE WASHER
24	C1592	1	INLET DEFLECTOR PLATE
25	SBI6441	2	Ø6 x 25 EXPANSION RIVET
26	M4X20SP	4	M4 x 20 SPAX
27	SBI6473	2	M8 HANDLE ADJUSTMENT KNOB
28	M6X40PPB	2	M6 x 40 POZIPAN SCREW BLACK
29	M6WB	2	M6 PLAIN WASHER BLACK
30	M8NUT	2	M8 NYLOC NUT
31	C1585	1	SQUEEGEE FOOTPEDAL ASSEMBLY
32	M4W	5	M4 PLAIN WASHER
33	M10X35BH	1	M10 x 35 HEX HEAD SCREW
34	C1611	1	FOOTPEDAL SPACER BUSH
35	M10X30W	2	M10 x 30 O/D WASHER
36	SBI6401	1	Ø40 TWIN PLASTIC WHEEL CASTOR
37	C1584	1	CASTOR WHEEL THREADED PIN
38	C1364	2	M8 x 4 SPACER
39	SBI6423	1	COMPRESSION SPRING
40	SBI6398	1	M8 HAND KNOB

WHEN ORDERING PLEASE QUOTE PART No. AND PART DESCRIPTION

V-WV35N 35L TANK ASSY WITH SQUEEGEE