

Victor



DOWDING & PLUMMER Ltd.

CALTHORPE HOUSE, STOCKFIELD ROAD,
BIRMINGHAM B27 6AP – ENGLAND

TEL: 0121-706-5771 FAX: 0121-708-1052

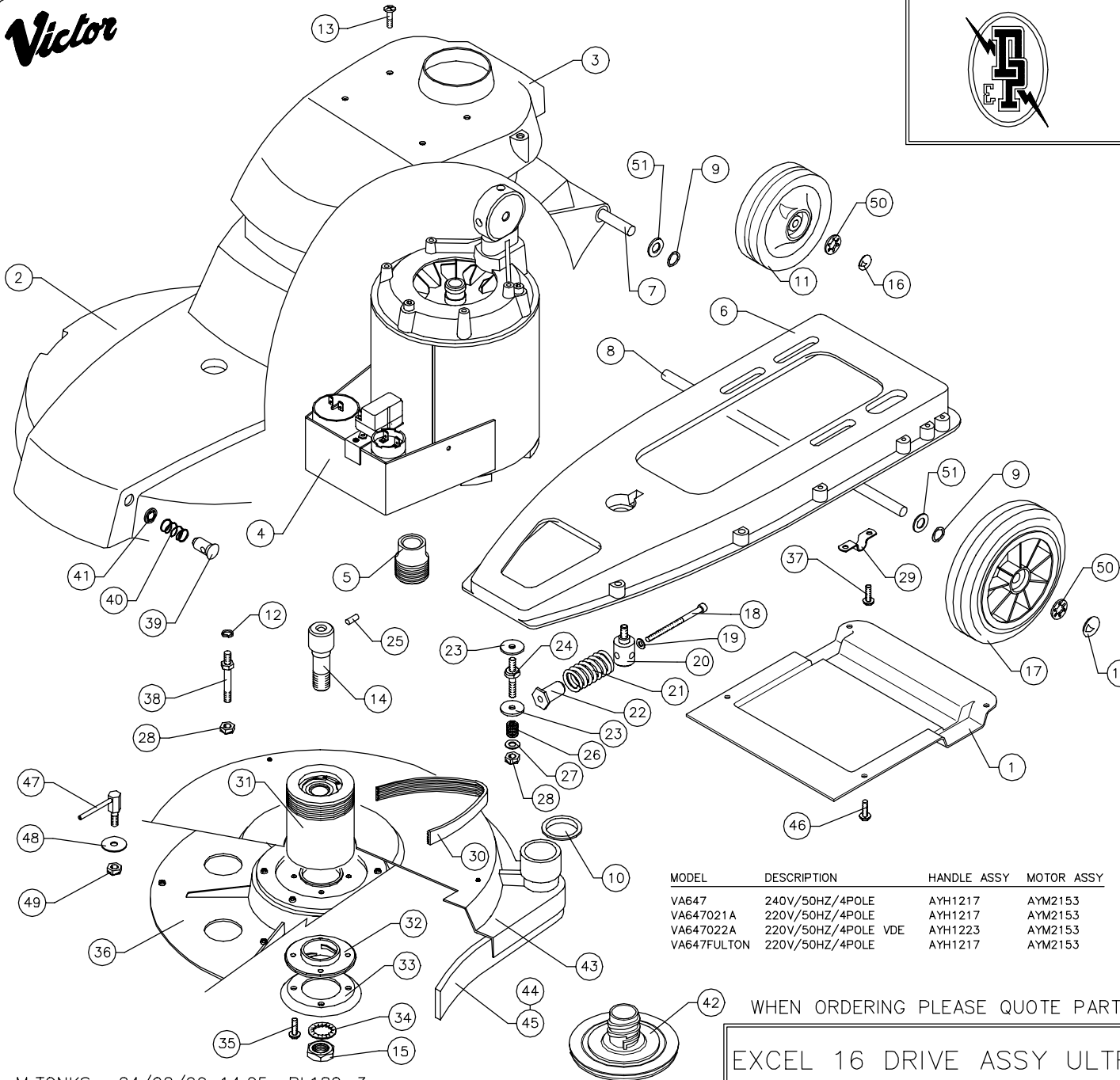

ITEM	PART No.	QTY.	DESCRIPTION
1	B1139	1	EXCEL BELT GUARD
2	B1133/RE	1	EXCEL 16" BODY MOULDING
3	C1729	1	EXCEL TOP COVER
4	SEE TABLE	1	MOTOR ASSEMBLY
5	A1955	1	MOTOR PULLEY #55mm x J8
6	B1145	1	EXCEL 16" BASE CASTING
7	A1878/PLTD	1	WHEEL AXLE (UPPER) 380mm
8	A1848/PLTD	1	WHEEL AXLE (LOWER) 420mm
9	SBI3666	4	WAVEY WASHER PLW4
10	A1926	1	PLASTIC CAP
11	A1880/BL	2	WHEEL #125
12	M8WSP	4	M8 SPRING WASHER
13	M6X12PPTT	4	M6 x 12 TAPTITE SCREW
14	A1872	1	EXCEL PULLEY BOLT
15	M20NH	1	M20 HALF NUT
16	A1934	4	PLASTIC WHEEL CAP – BLACK
17	C1587	2	WHEEL #175 REINFORCED BLACK
18	M6X125SC	1	M6 x 125 SOCKET CAP BOLT
19	M6N	1	M6 PLAIN WASHER
20	A1766	1	MOTOR PILLAR STUD
21	A1850	1	SPRING #30 x 50
22	A1865	1	SPRING RETAINER
23	A1378	7	PLAIN WASHER #30x#9x2.5
24	A1843	3	MOTOR STUD
25	SBI5550	1	SELOCK PIN 1/4" x 5/8"
26	A2132	3	SPRING #14 x 15
27	M8W	3	WASHER M8 PLAIN
28	M8NSB	7	M8 NUT – BINX
29	A1893	2	AXLE CLAMP
30	SBI5829	1	DRIVE BELT – 340J8
31	AYP1022	1	DRIVE PULLEY ASSY
32	B1164	1	RETAINER NUT
33	A1882	1	REINFORCING RING
34	M20WSH	1	M20 SHAKEPROOF WASHER
35	M6X25PPTT	4	M6 x 25 TAPTITE SCREW
36	AYD1007	1	EXCEL 16" DRIVE PLATE ASSY
37	M6X20TT	1	M6 x 20 TAPTITE SCREW
38	A1821	1	STUD
39	A1945	2	ANCHOR PIN (15mm) PLASTIC
40	A1620	2	SPRING #17 x 25
41	A1944	2	FIXING WASHER – #10mm
42	AYK1004	1	PAD RETAINER ASSY
43	AYD1005	1	16" DUST SHIELD
44	A1897	1	FELT FLOOR SEAL
45	A1927	1	DIFFUSER SEAL STRIP
46	M6X12TT	4	M6 x 12 TAPTITE SCREW
47	A1869	2	LEVER PIVOT BOSS
48	A1939	4	WASHER
49	M8NSB	2	M8 BINX STIFF NUT
50	A1936	4	1/2" FIXING WASHER
51	A1943	4	WASHER

MODEL	DESCRIPTION	HANDLE ASSY	MOTOR ASSY
VA647	240V/50HZ/4POLE	AYH1217	AYM2153
VA647021A	220V/50HZ/4POLE	AYH1217	AYM2153
VA647022A	220V/50HZ/4POLE VDE	AYH1223	AYM2153
VA647FULTON	220V/50HZ/4POLE	AYH1217	AYM2153

WHEN ORDERING PLEASE QUOTE PART No. AND PART DESCRIPTION

EXCEL 16 DRIVE ASSY ULTRA SP 240/220V – VA647 RANGE

FROM 24.02.99 TO