

Victor

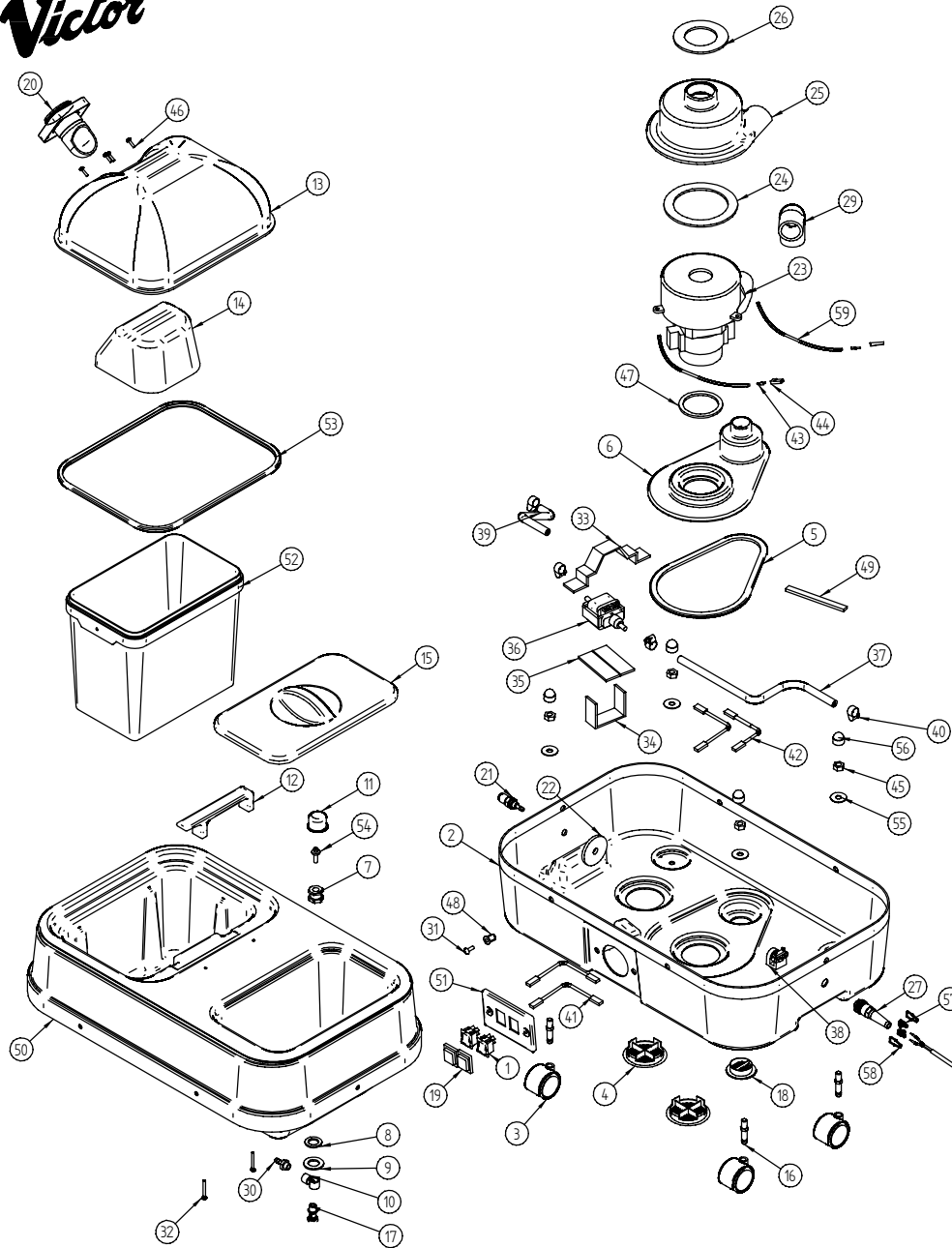

DOWDING & PLUMMER Ltd.

CALTHORPE HOUSE, STOCKFIELD ROAD,
BIRMINGHAM B27 6AP - ENGLAND
TEL: 0121-706-5771 FAX: 0121-708-1052

Item Number	Document Number	Quantity	Title	Item Number	Document Number	Quantity	Title
1	C1715	2	SWITCH 4 CONNECTOR	31	SBI6615	8	M6X6 BLK NYLON PAN PHILIPS SCREW
2	D0061	1	BOTTOM CASING	32	M4X35PP	2	M4x35PP SCREWS
3	SBI6612	4	CASTOR	33	D0122A	1	FOAM GASKET STRIP
4	SBI6391	2	LARGE VENT	34	D0122B	1	FOAM GASKET STRIP
5	D0168A	1	FOAM STRIP	35	D0122C	2	FOAM GASKET STRIP
6	D0067	1	INLET/EXHAUST FLANGE	36	SBI6580	1	PUMP - 50 psi
7	SBI6637	1	BAULKHEAD FITTING AND NUT	37	D0094G	1	HOSE
8	D0149	1	BANJO GASKET	38	SBI3928	1	CONCLAMP
9	M20W	1	M20 WASHER	39	D0094F	1	HOSE
10	SBI6638	1	FEMALE BANJO BODY	40	SBI3976	4	HOSE CLIP
11	SBI6589	1	MICRO MESH FILTER	41	SBI5565	3	PUMP TO SWITCH CABLE
12	B1356	1	HANDLE	42	C1835	1	PUMP CABLE WITH DIODE
13	D0068	1	INLET DOME	43	SBI3315	2	6.4mm FEMALE TAB
14	D0069	1	INLET DIFFUSER	44	SBI5932	2	6.4mm CABLE TAB BOOT
15	D0070	1	CLEAN WATER LID	45	M10N	4	CASTOR NUT
16	SBI6611	4	CASTOR STEMS	46	M4X16PP	4	M4x16 INTAKE FIXING SCREWS
17	SBI6639	1	MALE BANJO BOLT	47	D0150C	1	UNIVERSAL SEAL KIT
18	SBI6392	1	SMALL VENT	48	SBI6404	8	M6 SHORT JACKNUT
19	SBI6413	2	SPLASHPROOF COVER	49	D0168B	1	FOAM STRIP
20	SBI6616	1	INTAKE	50	D0160	1	UPPER CASING AND BUCKET ASSY
21	SBI6572	1	PANEL MOUNTING COUPLING	51	D0107	1	SWITCH PLATE
22	D0164	1	STRENGTH DISK PLASTIC	52	SBI6617	1	10LTR BUCKET
23	SBI6582	1	VAC MOTOR 1200W 2 STAGE	53	D0166A	1	CLEAR DOME SEAL
24	D0150A	1	UNIVERSAL SEAL KIT	54	D0075	1	FILTER ADAPTOR
25	D0065	1	MOTOR HOUSING	55	M10W	4	CASTOR WASHER
26	D0150B	1	UNIVERSAL SEAL KIT	56	SBI6613	4	POTECTION CAPS
27	SBI6409	1	CABLE RESTRAINT	57	SBI3726	2	PIGGY BACK TAG
28	C1095	1	INPUT POWER CORD	58	SBI3316	2	MALE INSULATOR
29	C1437	1	MOULDED ELBOW	59	SBI6669	2	VAC MOTOR 1200W CABLE
30	SBI6576	1	1/4" TO 6mm HOSETAIL				

WHEN ORDERING PLEASE QUOTE PART No. AND PART DESCRIPTION

CX10 ASSEMBLY 240V