

SPARE PARTS LIST

Victor SD40

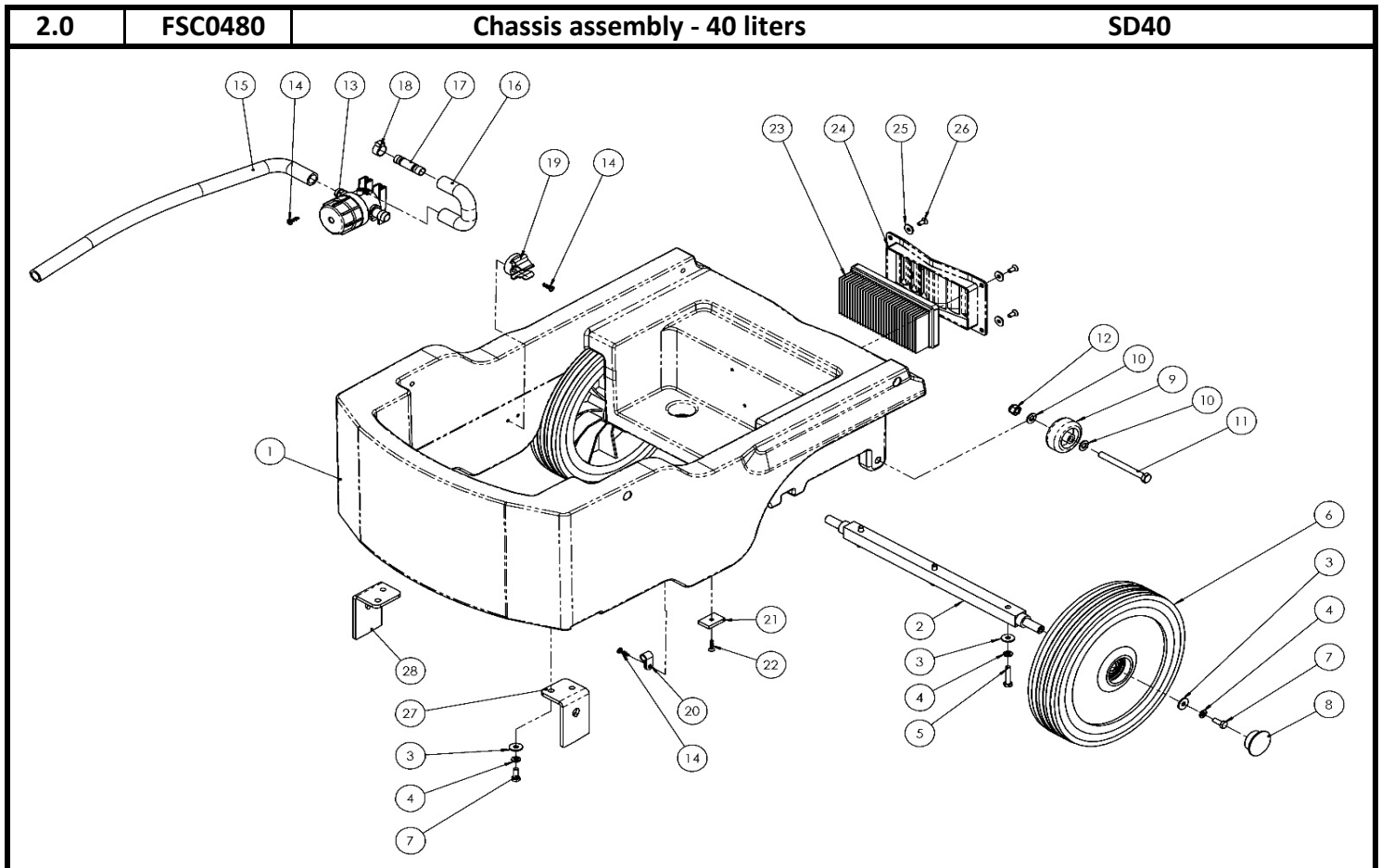



ID	Part number	Description	Quantity
1	FSC0640	Chassis 40 liters	1
2	FSC0670	Wheel axis 40 liters	1
3	FSC0400	Washer large 6x18 A2	9
4	FSC0060	Grower washer d.6	9
5	FSC0800	Hexagon screw M6x30	3
6	FSC0600	Ruota con cuscinetti d.250x50	2
7	FSC0520	Hexagon screw M6x16	6
8	FSC0030	Wheel cap	2
9	FSC0230	Wheel d.50x24	2
10	FSC0130	Washer d.8	4
11	FSC0660	Hexagon screw M8x85	2
12	FSC0020	Selflocking nut M8	2
13	FSC0020	Water filter	1
14	FSC0690	Screw TC 4x16	6
15	FSC0750	Water hose L= 580 mm	1
16	FSC0710	Water hose L= 280 mm	1
17	FSC0040	Extension d.12	1
18	FSC0330	Metal clamp 15x25	1
19	FSC0190	Hose support 17-20	1
20	FSC0280	Wire Mount 3/8"	2
21	FSC0650	Magnet 30x20x5	2
22	FSC0750	Screw TS 4x18	2
23	FSC0660	Air filter	1
24	FSC0150	Air flow discharging grid	1
25	FSC0810	Washer for counterscrew M5	4
26	FSC0460	Countersunk screw M5x12	4
27	FSC0950	Brush head holder - left	1
28	FSC0940	Brush head holder - right	1

2.0	FSC0410	Brush head 20"	SD40
------------	----------------	-----------------------	-------------

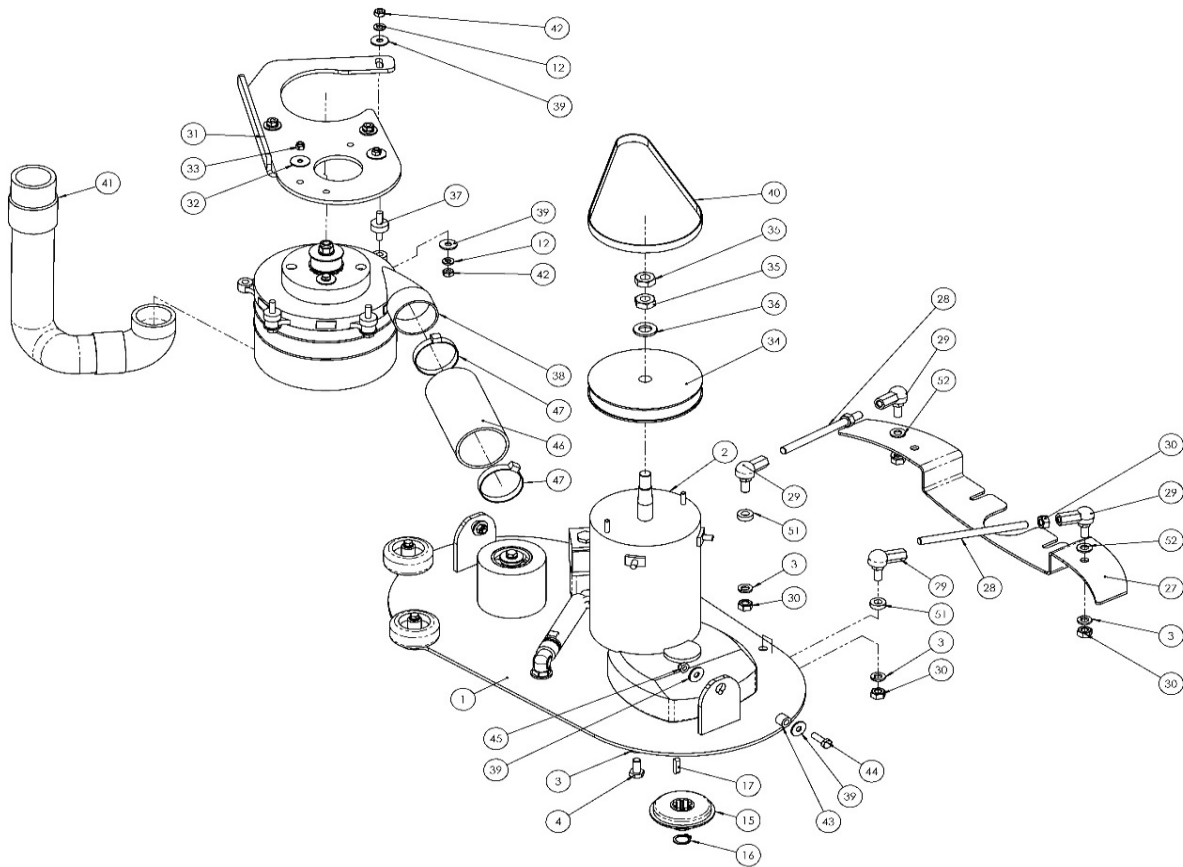

ID	Part number	Description	Quantity	
1	FSC0930	Brush deck 2x10"	1	
2	FSC0070	Gearbox motor 48V 500w	1	
3	FSC0110	Washer Grower d.8 A2 DIN 127	8	
4	FSC0370	Hexagonal screw M8x16	4	
5	FSC0590	Free shaft holder	1	
6	FSC0090	Ball bearing 6203-2RS	1	
7	FSC0220	Ball bearing 6302-2RS	1	
8	FSC0280	Gasket for rotating shaft	1	
9	FSC0600	Free shaft	1	
10	FSC0610	Spacer 17x25x33.5	1	
11	FSC0140	Washer large d.6x24	1	
12	FSC0060	Grower washer d.6	9	
13	FSC0170	Hexagon screw M6x12	3	
14	FSC0460	Countersunk screw M5x12	4	
15	FSC0050	Brush holder - small	2	
16	FSC0800	Seeger 15 E	2	
17	FSC0380	Shaft key 5x5x20 - A2	2	
18	FSC0030	Elbow "L" 3/8" d.12	1	
19	FSC0040	Extension d.12	1	
20	FSC0590	Solenoid valve holder	1	
21	FSC0530	Proportional solenoid valve 24Vdc	1	
22	FSC0480	Screw for plastic 5x9,5	2	
23	FSC0400	Transparent hose L=105mm	1	
24	FSC0330	Metal clamp 15x25	1	
25	FSC0230	Wheel d.50x24	2	
26	FSC0620	Spacer 8x6x28.5	2	
27	FSC1000	Squeegee holder - 40 liters	1	
28	FSC0570	Squeegee holder shaft	2	

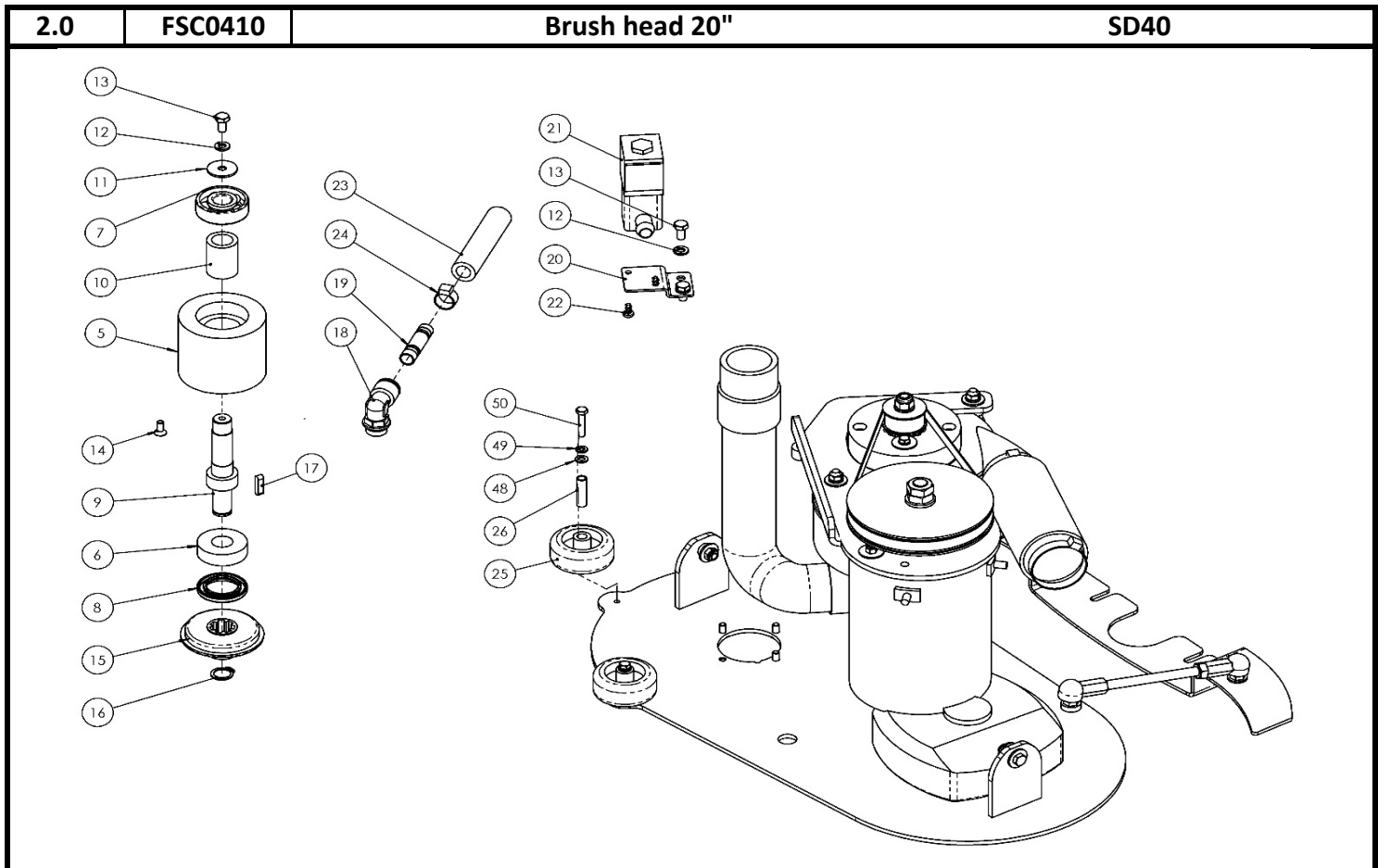

ID	Part number	Description	Quantity
29	FSC0640	Articuled head M8	4
30	FSC0670	Nut M8 A2 - DIN 982	6
31	FSC0960	Suction unit holder	1
32	FSC0190	Washer 5x20	2
33	FSC0220	Selflocking nut M5	2
34	FSC0720	Motor pulley	1
35	FSC0790	Nut M12	2
36	FSC0530	Washer d.12	1
37	FSC0300	Shock absorber 18x7,5 MM6	3
38	FSC0080	Suction turbine	1
39	FSC0400	Washer large 6x18 A2	10
40	FSC0590	Flat belt 530x10	1
41	FSC0520	Depression hose	1
42	FSC0350	Nut M6	6
43	FSC0580	Spacer 6.5x12x10.5	2
44	FSC0150	Hexagon screw M6x20	2
45	FSC0300	Selflocking nut M6	2
46	FSC0740	Air discharging hose, d50x160	1
47	FSC0340	Metal clamp 32x50	2
48	FSC0240	Washer d.5	2
49	FSC0200	Grower washer d.5	2
50	FSC0830	Hexagon screw M5x35	2
51	FSC0520	Spacer 8.25x16x5	2
52	FSC0130	Washer d.8	2

2.0 **FSC0490** **Tanks assembly - 40 liters** **SD40**

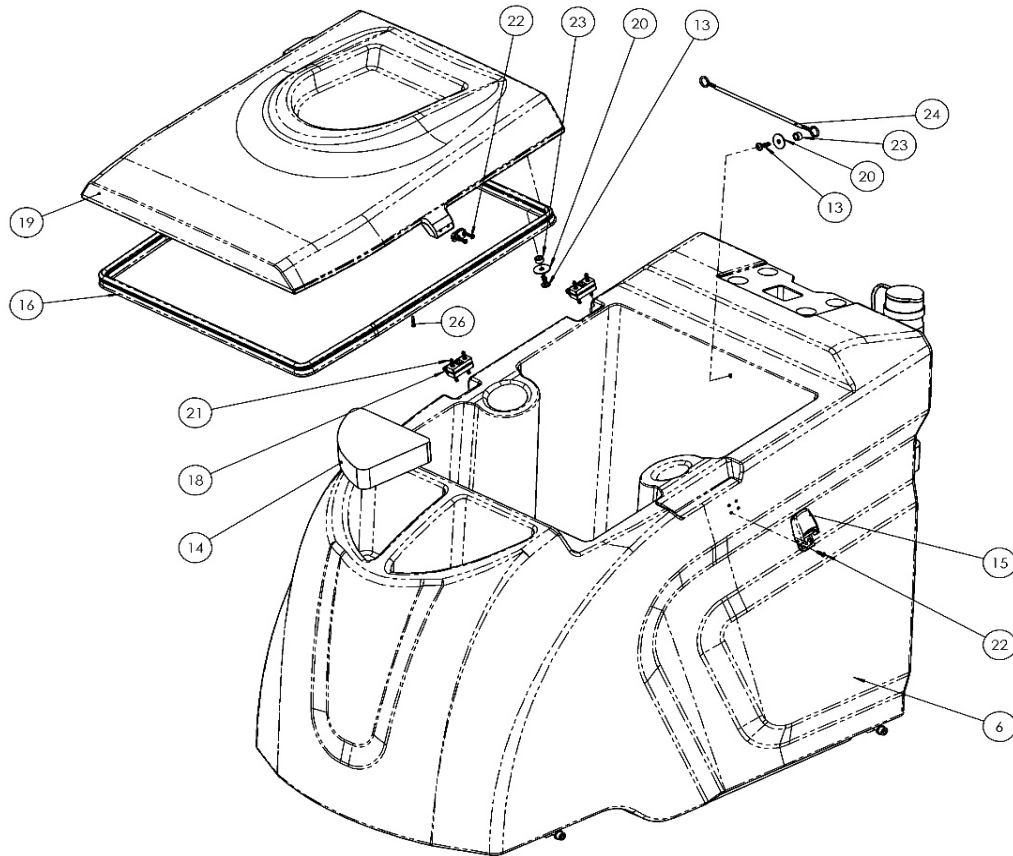

ID	Part number	Description	Quantity
1	FSC0630	Tank - 40 liters	1
2	FSC0060	Elbow dn.6	2
3	FSC0080	Tank gasket	2
4	FSC0550	Water level hose	1
5	FSC0510	Water level sensor	1
6	FSC0510	Drain hose	1
7	FSC0340	Metal clamp 32x50	1
8	FSC0120	Suction hose connector	1
9	FSC0690	Screw TC 4x16	9
10	FSC0130	Squegeee hose connector	1
11	FSC0280	Wire Mount 3/8"	3
12	FSC0990	Tank fixing plate	4
13	FSC0710	Screw TC 5x16	9
14	FSC0280	Filling water filter	1
15	FSC0630	Closure hook	1
16	FSC0270	Cap gasket - 40 liters	1
17	FSC0970	Counterweight	1
18	FSC0620	Hinge	2
19	FSC0650	Lid 40 liters	1
20	FSC0190	Washer 5x20	5
21	FSC0750	Screw TS 4x18	8
22	FSC0740	Screw TS 3x12 - A2	6
23	FSC0270	Spacer 6.2x10x5	2
24	FSC0300	Stainless steel cable	1
25	FSC0100	Elbow "L" 3/8" conic d.12	1
26	FSC0500	Self-threading screw 2,2x13	10
27	FSC0160	Washer 6	4
28	FSC0820	Hexagon screw M6x30	4

2.0 **FSC0490** **Tanks assembly - 40 liters** **SD40**

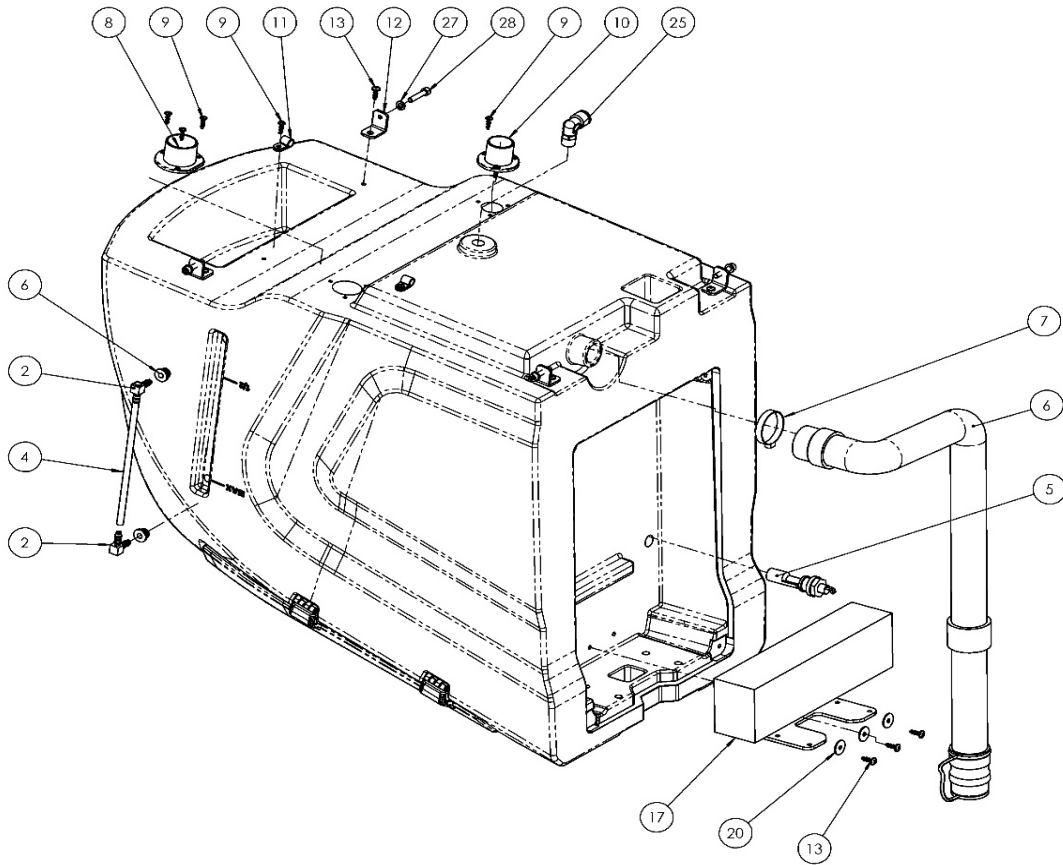

ID	Part number	Description	Quantity
1	FSC0630	Tank - 40 liters	1
2	FSC0060	Elbow dn.6	2
3	FSC0080	Tank gasket	2
4	FSC0550	Water level hose	1
5	FSC0510	Water level sensor	1
6	FSC0510	Drain hose	1
7	FSC0340	Metal clamp 32x50	1
8	FSC0120	Suction hose connector	1
9	FSC0690	Screw TC 4x16	9
10	FSC0130	Squegeee hose connector	1
11	FSC0280	Wire Mount 3/8"	3
12	FSC0990	Tank fixing plate	4
13	FSC0710	Screw TC 5x16	9
14	FSC0280	Filling water filter	1
15	FSC0630	Closure hook	1
16	FSC0270	Cap gasket - 40 liters	1
17	FSC0970	Counterweight	1
18	FSC0620	Hinge	2
19	FSC0650	Cap 40 liters	1
20	FSC0190	Washer 5x20	5
21	FSC0750	Screw TS 4x18	8
22	FSC0740	Screw TS 3x12 - A2	6
23	FSC0270	Spacer 6.2x10x5	2
24	FSC0300	Stainless steel cable	1
25	FSC0100	Elbow "L" 3/8" conic d.12	1
26	FSC0500	Self-threading screw 2,2x13	10
27	FSC0160	Washer 6	4
28	FSC0820	Hexagon screw M6x30	4

