

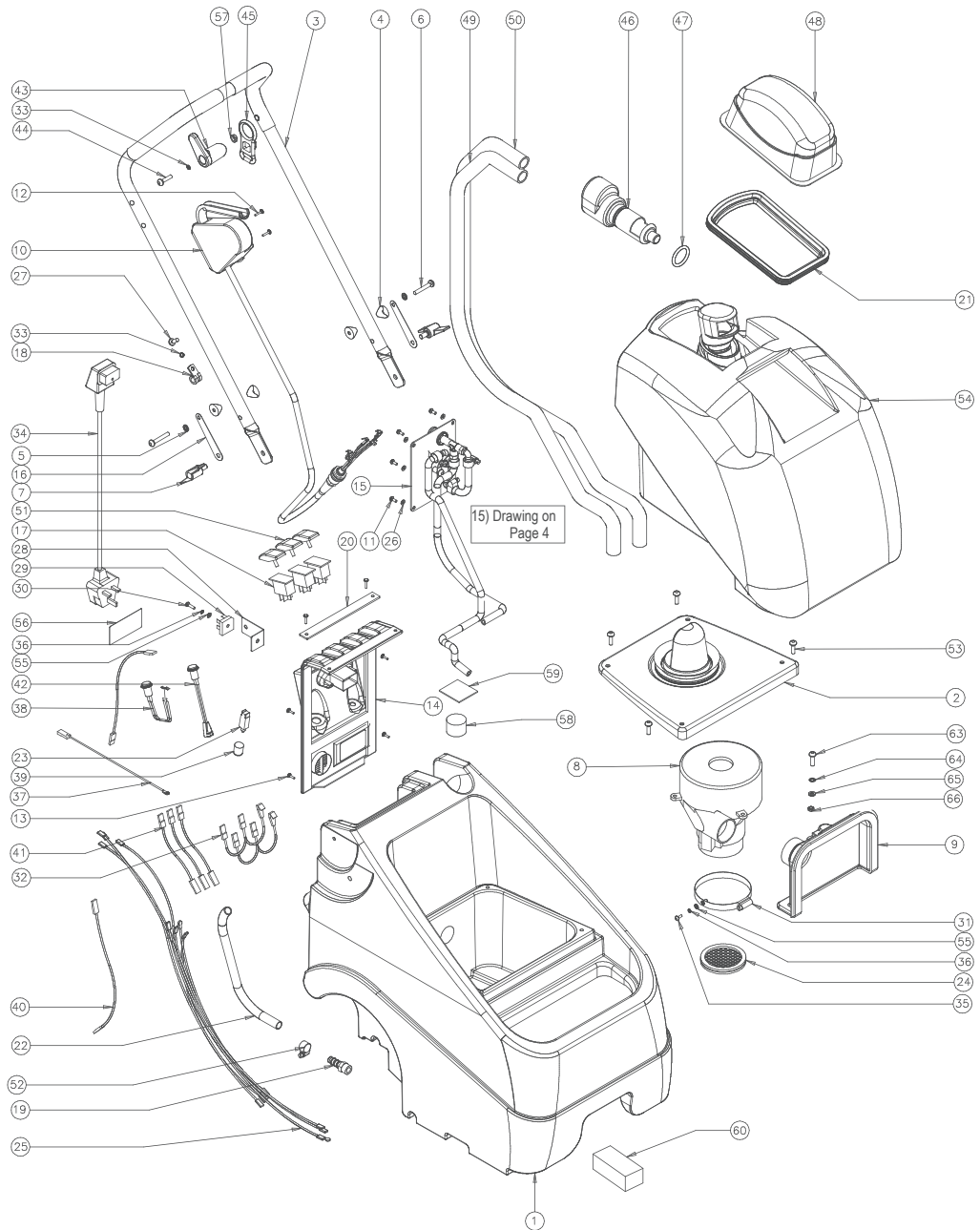

IIC Products Ltd
 T/A Victor Floorcare
 Unit 15 & 16
 Ace Business Park
 Mackadown Lane
 Birmingham
 B33 0LD
 www.victorfloorcare.com

sales@victorfloorcare.com
 +44 (0)121 706 5771
 www.VictorFloorcare.com



ITEM	PART No.	QTY.	DESCRIPTION	ITEM	PART No.	QTY.	DESCRIPTION
1	D0308	1	BOTTOM TANK	34	D0516	1	MAINS CABLE ASSY
2	D0340	1	MANIFOLD ASSY	35	M4X10SPB	1	M4X10 POZIPAN SCREW BRASS
3	D0430	1	HANDLE ASSY	36	M4WSH	2	M4 SHAKEPROOF WASHER
4	SBI6433	4	SADDLE WASHER	37	D0546	1	EARTH CABLE ASSY
5	M6WB	2	M6 PLAIN WASHER BLACK	38	D0538	1	GREEN NEON LIGHT
6	M6X40PPB	2	M6X40 POZIPAN SCREW BLACK	39	SBI6839	1	SWITCH COVER
7	D0495	2	HANDLE ADJUST KNOB	40	C1836	2	PUMP LIVE CABLE
8	SBI6582	1	VAC MOTOR	41	D0507	3	SWITCH CABLE
9	D0504	1	EXHAUST MANIFOLD ASSY	42	D0552	1	AMBER NEON LIGHT
10	D0518	1	HANDLE SWITCH ASSY	43	D0390	1	CABLE HOOK
11	M4X10PPB	4	M4X10 POZIPAN SCREW BLACK	44	M6X25PPB	1	M6X25 POZIPAN SCREW BLK
12	SBI6860	4	PT SCREWS	45	D0550	1	CABLE RESTRAINT
13	SBI6840	4	PT SCREWS	46	D0655	1	INLET HOSE ADAPTOR
14	D0432	1	ELECTRICAL ENCLOSURE ASSY	47	SBI6895	1	O'RING
15	D0433	1	COUPLING PLATE ASSY	48	D0647	1	DOME
16	D0438	2	HAND KNOB RETAINER	49	D0601B	1	SQUEEGEE PIPE
17	SBI6810	3	ROCKER SWITCH 2 POSITION	50	D0601B	1	SQUEEGEE PIPE
18	SBI6698	1	CABLE GUIDE HOOK	51	SBI6886	3	SWITCH ACTUATOR
19	SBI6813	1	HOSETAIL	52	SBI3976	1	HOSE CLIP
20	D0464	1	ELECTRICAL ENCLOSURE STRAP	53	M6X20PPSS	4	M6X20 POZIPAN SCREW
21	D0357A	1	CLEAR DOME SEAL	54	D0707	1	TOP TANK ASSY
22	D0465/A	1	DUMP HOSE	55	M4W	2	M4 PLAIN WASHER
23	SBI6831	1	1AMP BREAKER RESET	56	C1386	1	SERIAL NUMBER LABEL
24	D0502	1	MOTOR SEAL ASSY	57	M8N	1	M8 NUT
25	D0503	1	WIRING LOOM	58	D0895	1	VAC CHAMBER FOAM BUNG
26	M4WB	4	M4 WASHER BLACK	59	D0527E	1	GASKET SEAL
27	M6X16PP	1	M6X16 POZIPAN SCREW	60	D0896	1	BASE COVER FOAM BUNG
28	D0496	1	RECTIFIER BRACKET	63	M6X20PP	1	M6X20 POZIPAN SCREW
29	SBI6177	1	RECTIFIER	64	M6W	1	M6 PLAIN WASHER
30	M4X16PP	1	M4X16 POZIPAN SCREW	65	M6WSH	1	M6 SHAKEPROOF WASHER
31	D0511	1	EARTH BOND STRAP ASSY	66	M6N	1	M6 NUT
32	C1837	2	INTERTERMINAL CABLE				
33	M6WSP	2	M6 SPRING WASHER				

A.G.D.

PL476-1

WHEN ORDERING PLEASE QUOTE PART No. AND PART DESCRIPTION



RANGE

V-SX15

15Ltr SPRAY EXTRACTOR TANK ASSEMBLY



IIC Products Ltd
T/A Victor Floorcare
Unit 15 & 16
Ace Business Park
Mackadown Lane
Birmingham
B33 0LD

sales@victorfloorcare.com
+44 (0)121 706 5771

www.VictorFloorcare.com

www.victorfloorcare.com

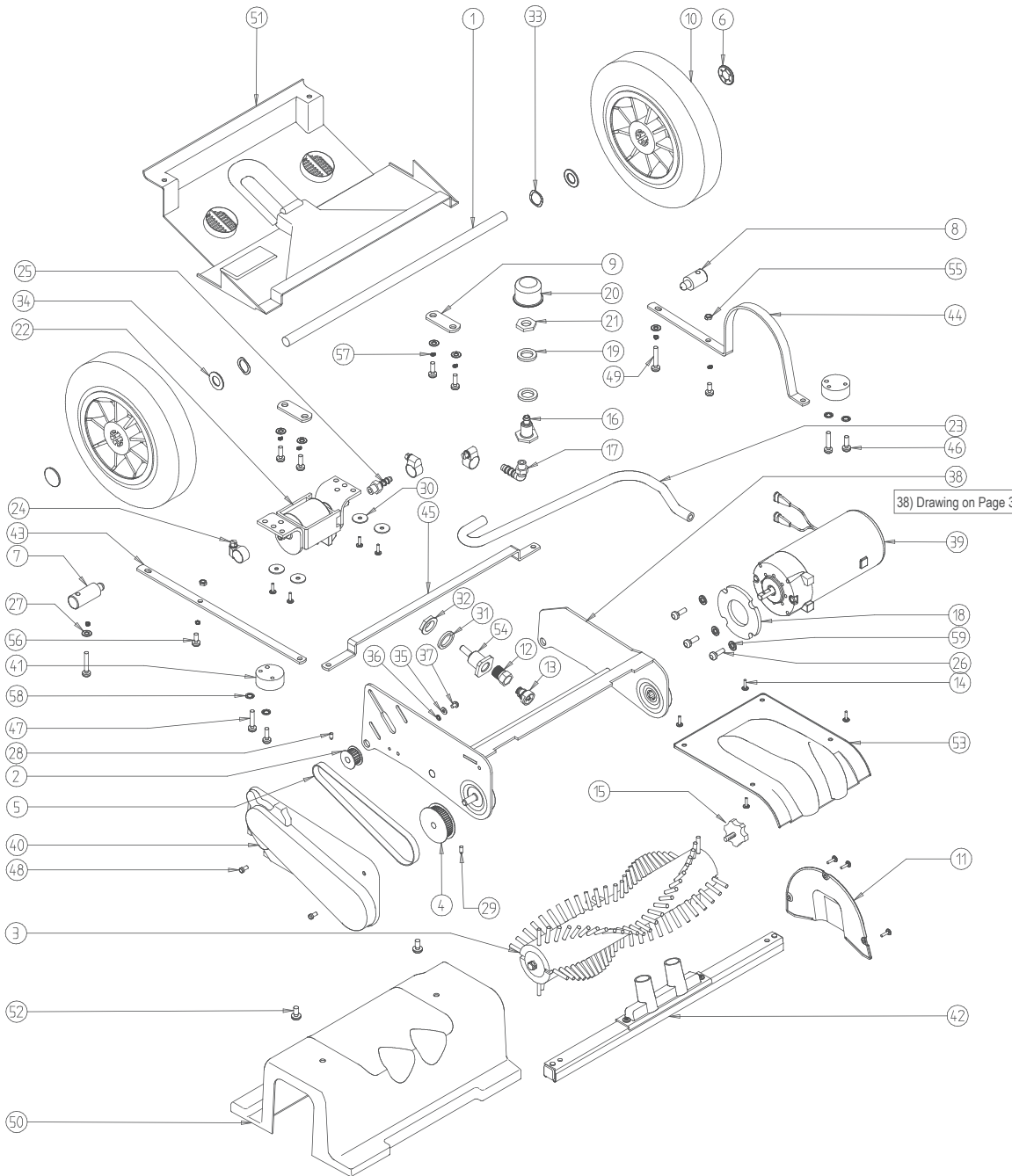

ITEM	PART No.	QTY	DESCRIPTION	ITEM	PART No.	QTY	DESCRIPTION
1	D0564	1	WHEEL AXLE	31	D0528	1	RUBBER SPACER
2	D0466	1	PULLEY DIA 25	32	SBI6861	1	HEX WASHER FACED NUT
3	C4107	1	CARPET BRUSH ROLL	33	SBI3666	2	WAVEY WASHER - PLW4
4	D0467	1	BRUSH PULLEY	34	M12W	2	M12 PLAIN WASHER
5	SBI6829	1	DRIVE BELT	35	M4WB	1	M4 WASHER BLACK
6	SBI3005/A	2	12mm STARLOCK CAP	36	M4WSH	1	M4 SHAKEPROOF WASHER
7	D0358	1	BRUSH BRACKET SPACER	37	M4X6PPB	1	M4x 6 POZIPAN SCREW BRS
8	D0337	1	BRUSH BRACKET SPACER	38	D0792	1	BRUSH FRAME ASSY.
9	C1561	2	WHEEL AXLE LOCATION PLATE	39	D0452	1	DRIVE MOTOR
10	SBI6101/NT	2	8" DIA WHEEL	40	D0509	1	BELT COVER ASSY
11	D0814	1	BRUSH ROLL END PLATE	41	D0664	2	SPACER
12	SBI6801	1	SPRAY NOZZLE BODY	42	D0668	1	FRONT PICK UP ASSY
13	SBI6802	1	SPRAY NOZZLE	43	D0592	1	SQUEEGEE SUPPORT ARM RH
14	SBI6840	11	PT SCREWS	44	D0586	1	SQUEEGEE SUPPORT ARM LH
15	D0809	1	BRUSH RELEASE KNOB ASSY.	45	D0669	1	CROSS BAR
16	D0439	1	TANK OUTLET	46	M5X16PPSS	2	M5x16 PP SS
17	SBI6764	1	MALE ELBOW	47	M5X25PPSS	2	M5x25 PP SS
18	D0453	1	MOTOR SPACER	48	M5X8PPSS	2	M5x8 POZIPAN SCREW SS
19	D0457	2	TANK OUTLET GASKET	49	M5X30PPSS	2	M5x30 PP SS
20	SBI6814	1	MICRO MESH FILTER ST ST	50	D0676	1	BRUSH COVER
21	SBI6818	1	NYLON NUT	51	D0700	1	BASE COVER ASSY
22	D0924	1	PUMP & TEMP. TRIP ASSY.	52	M6X12PPSS	2	M6X12 POZIPAN SCREW SS
23	D0094I	1	OUTLET TO PUMP HOSE	53	D0702	1	EXHAUST PLATE
24	SBI3976	3	HOSE CLIP	54	D0437	1	SPRAY BODY ADAPTOR
25	SBI6786	1	STRAIGHT CONNECTOR	55	M5NSS	2	M5 NUT SS
26	M5X16PP	7	M5x16 POZIPAN SCREW	56	M5X12PPSS	2	M5x12 POZIPAN SCREW
27	M5W-SS	9	M5 WASHER - STAINLESS	57	M5WSP	8	M5 SPRING WASHER
28	M4X6SDP	1	SOCKET SET SCREW DOG PT	58	M5WSH-SS	5	M5 STAINLESS SP WASHER
29	M4X10SDP	1	SOCKET SET SCREW DOG PT	59	M6W	3	M6 PLAIN WASHER
30	3/16x3/4W	4	3/16"x3/4" PLAIN WASHER				

A.G.D.

PL477-1

WHEN ORDERING PLEASE QUOTE PART No. AND PART DESCRIPTION



RANGE

V-SX15

15Ltr SPRAY EXTRACTOR

BRUSH DRIVE & SHOE ASSY

APPROVED
 QUALITY MANAGER

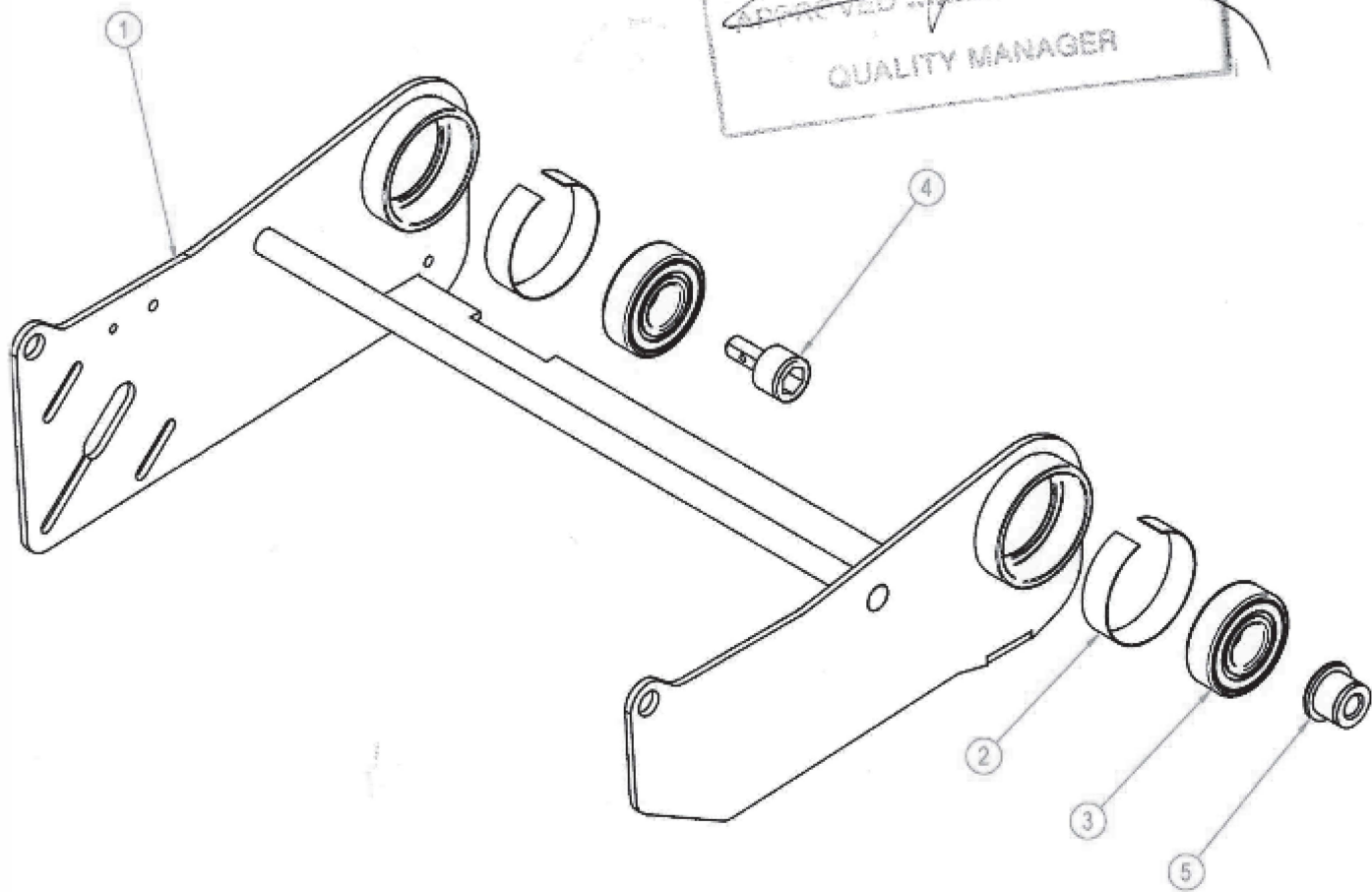

Item Number	Document Number	Title	Quantity
1	D0717	CARPET EXTRACTOR FRAME ASSY	1
2	SBI3296	40mm STAR TOLERANCE RING	2
3	SBI3290	LJ 17mm BEARING	2
4	D0345	PULLEY DRIVE INSERT	1
5	D0711	BUSH INSERT	1

A.BARTON 15/07/03 14.40 D0792-1

A3

ISSUE 1

BRUSH FRAME ASSY

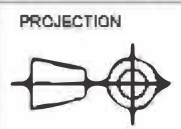

TOLERANCE LIMITS	ANGLES
X	± 0.2 mm
X.X	± 0.1 mm
X.XX	± 0.05 mm
ANGLES	± 1°

SCALE
 1:2

MATERIAL
 -

TITLE
 BRUSH FRAME ASSY

DRAWN BY
 A.BARTON
 DATE

DRAWING NUMBER
 D0792

ISSUE
 1

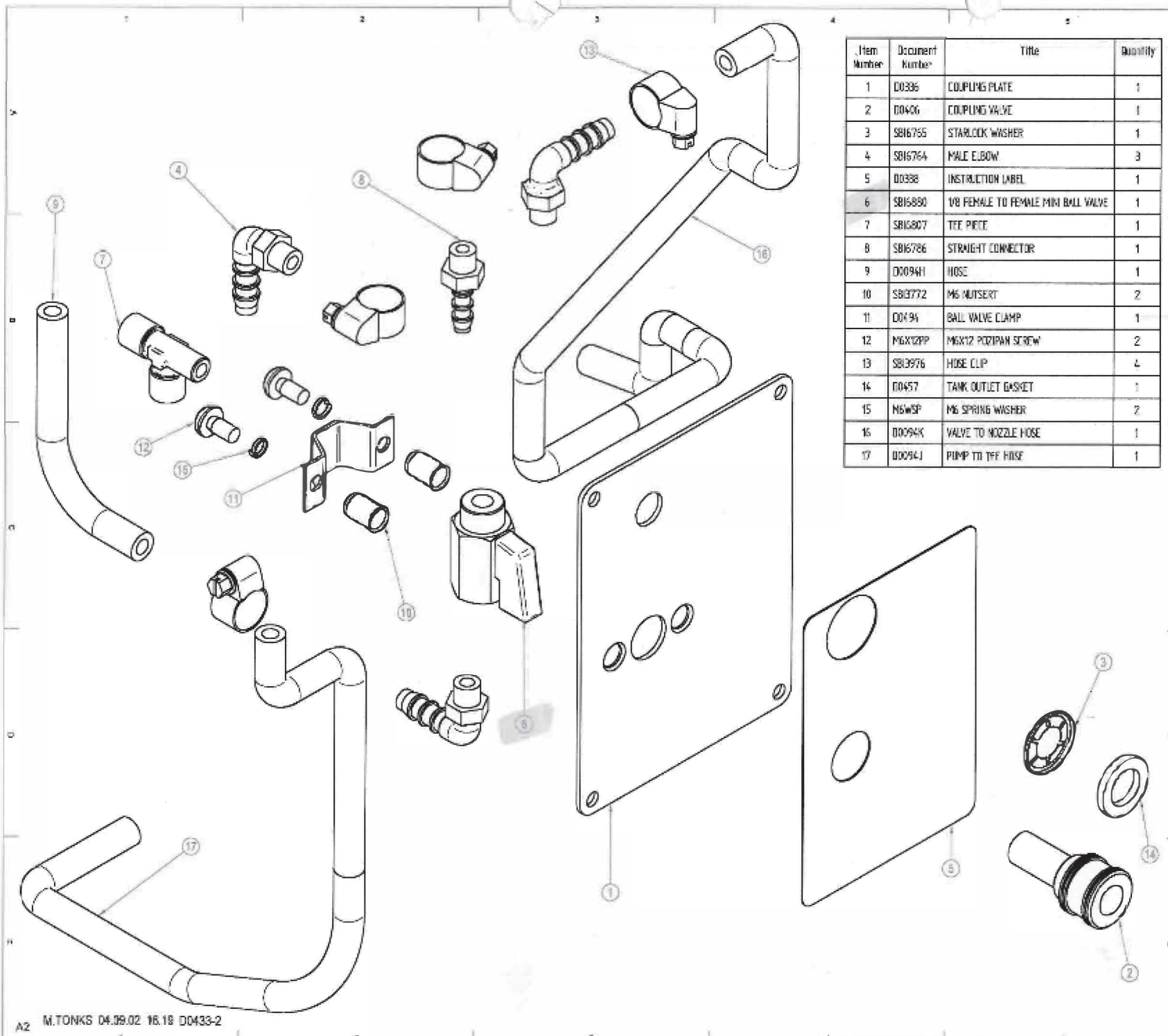

Item Number	Document Number	Title	Quantity
1	D0336	COUPLING PLATE	1
2	D0406	COUPLING VALVE	1
3	SB16755	STARLOCK WASHER	1
4	SB16764	MALE ELBOW	3
5	D0338	INSTRUCTION LABEL	1
6	SB16890	1/8 FEMALE TO FEMALE MIN BALL VALVE	1
7	SB16807	TEE PIECE	1
8	SB16786	STRAIGHT CONNECTOR	1
9	D00941	HOSE	1
10	SB03772	M6 NUTSERT	2
11	D0436	BALL VALVE CLAMP	1
12	M6X12PP	M6X12 POTPAN SCREW	2
13	SB13976	HOSE CLIP	4
14	D0457	TANK OUTLET GASKET	1
15	M6WSP	M6 SPRING WASHER	2
16	D0094K	VALVE TO NOZZLE HOSE	1
17	D0094J	PUMP TO TEE HOSE	1

ISSUE	DATE	NOTES	APP	WAPP
1	06.06.20	PRODUCTION	AS	RD
2	04.03.02	ITEM No 8 888888 WAS 288888		

ISSUE 2

THIS DRAWING IS THE PROPERTY AND COPYRIGHT OF:
ROBINSON & MURPHY LTD
 100, BRIDGE STREET, BIRMINGHAM B1 2JY
 TEL: 0121 633 1000 FAX: 0121 633 1001
 E-MAIL: SALES@R&M.CO.UK

PROJECTION 	TOLERANCES WHERE NOT GIVEN h ± 0.2 mm k ± 0.1 mm ANGLES ± 1°
----------------	---

SCALE 1:1	MATERIAL SEE DWGS
--------------	----------------------

TITLE
COUPLING PLATE ASSEMBLY